

Feed-in Tariff Mechanisms for Mini-Grid Markets

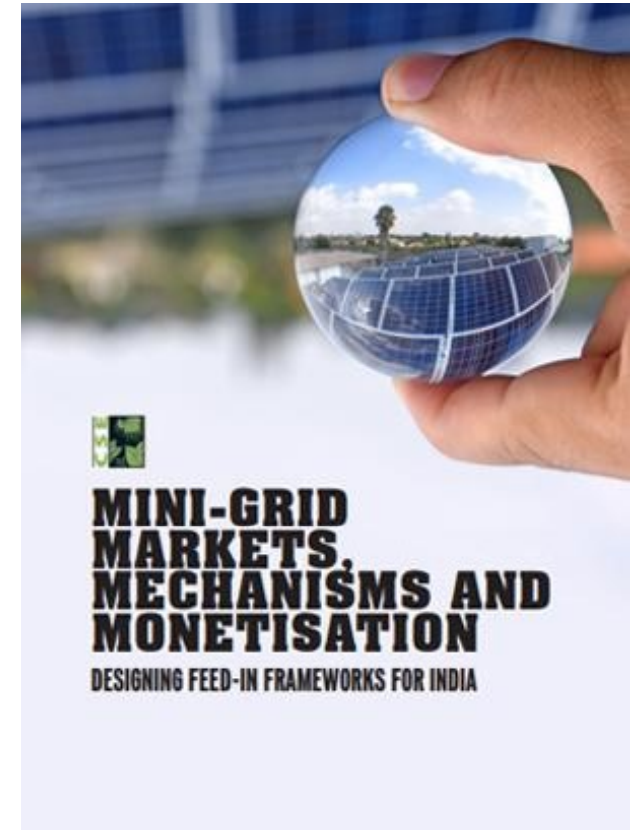

Centre for Science and Environment

The Mini-Grid Business and Financing Models |
June 03, 2026



Previously discussed...

666M

people globally without electricity access (2024)

490M

could be most cost-effectively served by mini-grids by 2030

6–9 months

mini-grid deployment vs 5–8 years for grid extension

95%

fall in solar module prices since 2010 (now <\$0.10/W)
solar mini-grids cost around Rs 15 per unit to deliver electricity

- Solar Mini-grids compete with diesel generation (Rs 25–40/kWh) and commercial 3-phase discoms tariffs (Rs 9–15/kWh) — making them viable for commercial activities viz. agricultural processing, cold storage, and rural enterprises etc.

From Pilot to Shutdown

Indrapur Island, WB	Dharnai, Bihar	Patharpara, WB	Ravan Village, CG	Darewadi, Pune MH	Barapitha, Odisha
<p>2004- 2019 Served 120 homes. Grid came 2018.</p> <p>~~~~~</p> <p>110 kWp solar asset stranded; no grid-interactive transition plan was ever made</p>	<p>2014 – 2018 Media-famous 'solar village'. Batteries died, subsidized grid killed tariffs.</p> <p>~~~~~</p> <p>Community lost energy sovereignty - now fully dependent on an unreliable subsidised grid</p>	<p>2017- 2022 Unregulated grid arrival → customers fled → revenue collapsed.</p> <p>~~~~~</p> <p>Land earmarked for productive use (agriculture/beekeeping) remains idle due to inactive installations</p>	<p>2010–2020 Panels stolen, community left. CREDA dismantled it.</p> <p>~~~~~</p> <p>CREDA dismantled & repurposed components - community received no compensation or replacement</p>	<p>2012 - 2022 New batteries in 2019. Grid arrived 2021. No feed-in tariff = instant death.</p> <p>~~~~~</p> <p>9.36 kWp system lost economic relevance despite battery replacement investment in 2019</p>	<p>2015- 2018 Cyclone damage + no maintenance funds + grid = abandoned.</p> <p>~~~~~</p> <p>Severely damaged in Cyclone Fani 2017; no disaster recovery fund = permanent abandonment</p>

Functional mini-grids that shut down after the national grid arrived

- India built hundreds of solar mini-grids to give electricity to remote villages.
- These systems worked : powering homes, shops, and schools for years.
- Then the national grid arrived and the mini-grids simply died.
- Not because they failed technically — but because there was NO policy to protect them.
- Investors lost money. Villages lost local expertise. Assets were abandoned.



THE GRID ARRIVAL PARADOX

India has 100+ defunct mini-grids. Not because they failed technically — but because regulation failed them.

No Feed-in Tariff

Mini-grids cannot sell surplus power to DISCOMs. No revenue stream survives grid arrival.

No Buyout Formula

No asset valuation or compensation mechanism when the grid takes over.

No Franchise Model

Functioning distribution infrastructure is abandoned rather than integrated.

80–90% Customer Loss

Subsidized grid tariffs of Rs 5–7/kWh vs mini-grid rates of Rs 10–20/kWh cause immediate defection.

- **All four of these costs - generation, storage, distribution, & civil work - land on the mini-grid developer alone. That's why mini-grid power is expensive. That's the problem we need to solve.**

WHY IS MINI-GRID POWER SO EXPENSIVE?



Generation (Solar panels, inverters)



Battery Storage



Distribution Infrastructure



Construction & Other



*Unlike big power plants, mini-grids also have to build the last-mile distribution network themselves. That's **30% extra cost** that a regular utility never has to worry about!*

The Tariff Reality:

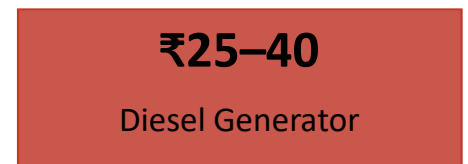

What Did Other Countries Do Right?

Nigeria — Tripartite Model



Three-way agreement between developer, DISCOM & community. If grid arrives, DISCOM must pay: full depreciated value + 1 year's revenue.

Cambodia — Distribution Franchise



Mini-grids required to build 'grid-ready' poles & wires. When grid arrives, they simply stop generating and BUY bulk power — but keep running the local distribution.

Tanzania — Small Power Producer



Mini-grids can sell surplus power back to the utility. During grid outages, they go 'island mode' — giving customers better reliability than the national grid

Kenya — Hybrid PPP



Private developers build & operate for 7–10 years. Customers pay national tariff from Day 1. Utility buys bulk power. After concession, utility takes over assets.

Common thread: Regulatory predictability. Developers know the rules before they invest.



FIXING THE MONEY PROBLEM

How you finance a mini-grid determines whether it survives

Option 1 Commercial debt financing	Option 2 Blended Finance	Option 3 Maximum concessional finance
₹14.41/kWh 100% commercial debt at 9% interest with 12-year tenure	₹12.10/kWh 25% grant + 25% cheap Development Finance Institution loan + 50% private equity @12%	₹8.76/kWh 50% grant + 50% cheap DFI loan No equity burden
Viable	Better	Competitive

Scenario	LCOE (₹/kWh)	Cost Reduction
Scenario 1: Commercial debt	Rs 14.41	Baseline
Scenario 2: Blended finance	Rs 12.10	16.0% lower
Scenario 3: Concessional finance	Rs 8.76	39.2% lower

*Key insight: It's not about charity — it's about the right mix of grants, cheap loans, and investor money.
 Nigeria's RBF model pays \$600 per connection ONLY after verified electricity delivery — no output, no money.*

FOUR PATHWAYS WHEN THE GRID ARRIVES



01

Parallel Operation

Continue serving customers on a separate distribution network alongside the grid. Viable where grid reliability remains poor. Customers pay a reliability premium.

02

Independent Power Producer

Shift from retail to wholesale generation. Sell electricity to the main grid at regulator-approved feed-in tariffs. Exit the retail business entirely.

03

Energy Service Company

Become a contracted distribution operator for the DISCOM. Manage last-mile metering, billing, and collections where direct utility operation isn't economical.

04

Asset Transfer & Exit

Sell physical infrastructure to the DISCOM at depreciated book value plus 12-month revenue equivalent — Nigeria's investor-protection formula.

India currently provides no structured pathway for any of these transitions. Outcomes are left to ad hoc negotiations.

Mini-Grid Interconnection with the Main Grid

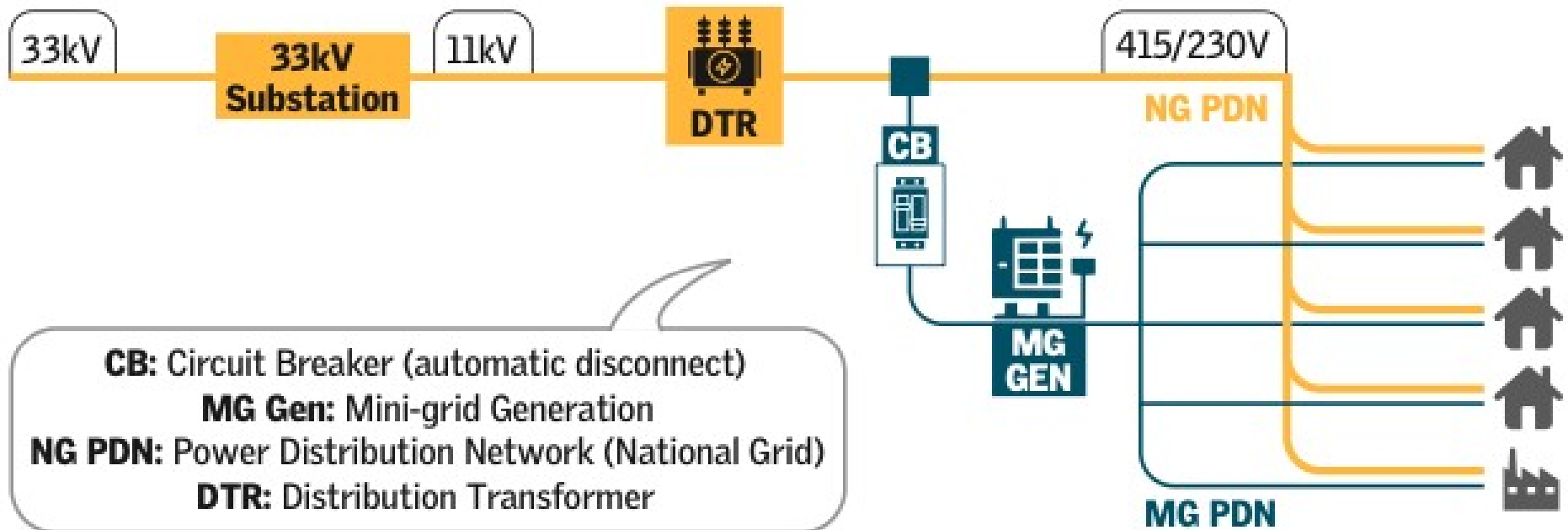

The circuit breaker enables automatic islanding - letting the mini-grid operate independently or in parallel with the national grid

Mini-Grid Interconnection with the Main Grid – Interconnection at the **LT Network**

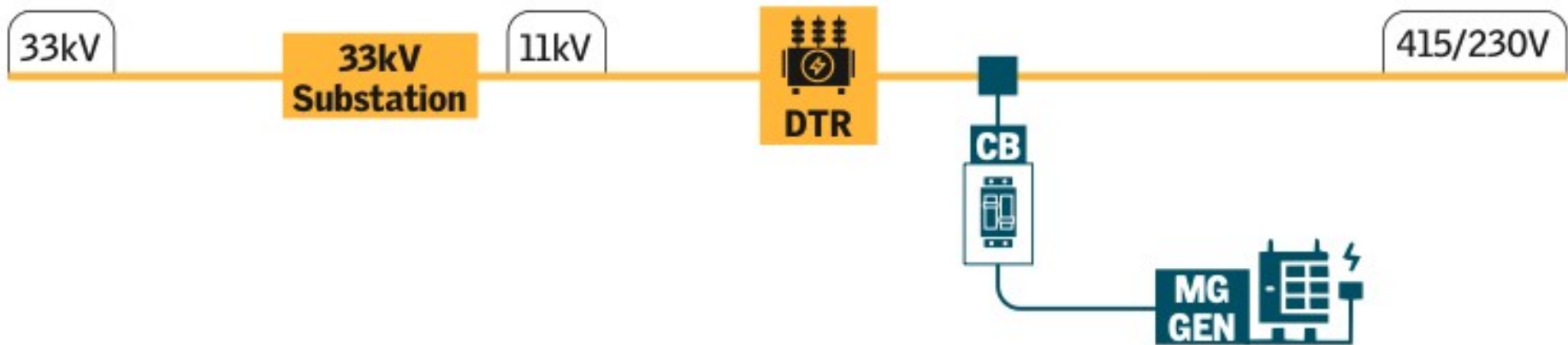

LT interconnection connects the mini-grid closest to the generation — lower losses, lower cost. But it only works where rural feeders are live and reliable

Mini-Grid Interconnection with the Main Grid – Interconnection at the **11kV Network**

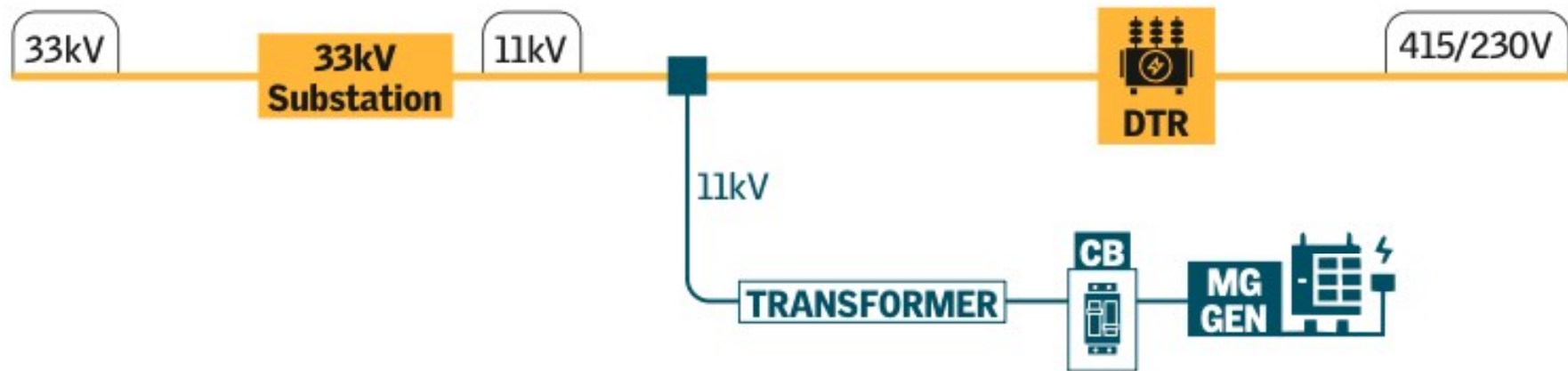

More robust than LT, but the added transformer + kilometres of cabling can cost up to ₹15 lakhs — a burden operators bear alone, making it financially unviable for most private developers

What India Needs to Do — NOW

Short Term

Register mini-grids <100 kW with simple community sign-off — no bureaucratic jungle

Publish open-source tariff tools so developers can model costs before investing

DISCOMs must publish grid expansion timelines — developers deserve to know what's coming

Medium Term

Deploy blended finance: 20–40% grant + 30–50% cheap loan + 20–40% private equity

Results-Based Financing: Pay a certain amount per connection ONLY after 6 months of verified supply

Train state regulators on mini-grid economics — most have no idea how to evaluate these projects

Long Term

After Dec 2025 India rule: treat mini-grid batteries as grid infrastructure — they provide voltage & frequency support

Mini-grids become distribution franchise nodes in India's energy system

States have tendered 13 GWh of battery storage — mini-grids already have this. Just connect them!

THANK YOU



Binit Das

binit.das@cseindia.org

+91 8093326269

cseindia.org/page/renewable-energy

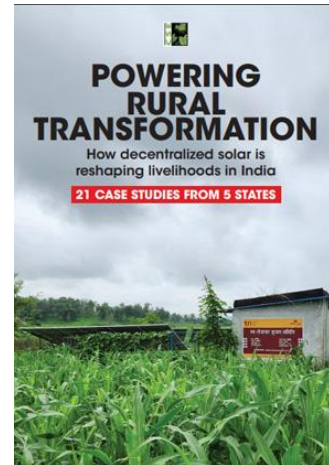

Download the full report to see how these models work on the ground.



Download the full report to understand how feed-in tariff frameworks operationalize.

